



ZEV & ZEV-B cable gland

Presse étoupe d'amarrage ZEV & ZEV-B

IP PROTECTION :
IP 65 without flat seal

OPERATING TEMPERATURE :
-40 °C / +60 °C

SPECIAL FEATURES :

- Bending protection
- Increased strain relief

MATERIAL :

- Nickel-plated brass
- Peelable sealing : rubber
- Galvanized steel washer

THREAD :
Metric, PG

CERTIFICATION :
IEC 62 444

ACCESSORIES AVAILABLE :
See accessories

INDICE DE PROTECTION :
IP 65 sans joint plat

PLAGE DE TEMPÉRATURE :
-40 °C / +60 °C

AVANTAGES TECHNIQUES :

- Protection renforcée en cas de flexion du câble
- Résistance à la traction

MATIÈRE :

- Laiton nickelé
- Garniture pelable : caoutchouc
- Rondelle : acier zingué

FILETAGE :
Métrique, PG

CERTIFICATION :
IEC 62 444

ACCESSOIRES DISPONIBLES :
Voir page des accessoires

OTHER APPLICATIONS

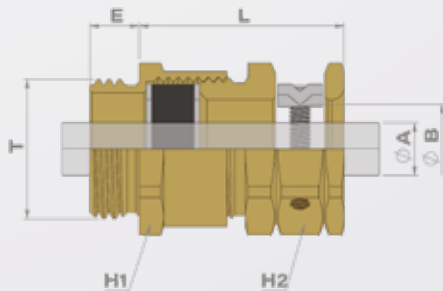

ZEV



	Thread T	Part Number	Clamping range		H1	H2	E	L	Packing
			Ø A (sealing)	Ø B (squeezing)					
Metric	16	C8116090	3,5 / 9,0	4,0 / 9,0	18	17	7,0	19,0	50
	20	C8120110	3,5 / 11,0	7,0 / 11,0	22	20	7,0	19,0	50
	20	C8120130	5,5 / 13,0	10,0 / 13,0	22	22	7,0	21,0	50
	25	C8125160	6,5 / 15,0	10,0 / 15,0	27	24	8,0	20,0	50
	25	C8125210	8,0 / 20,0	13,0 / 20,0	32	30	8,0	22,0	50
	32	C8132210	8,0 / 20,0	13,0 / 20,0	34	30	8,5	23,5	10
	32	C8132290	12,5 / 29,0	20,0 / 29,0	40	40	8,5	37,5	10
PG	07	C8107008A	4,0 / 6,0	6,0 / 9,0	14	17	5,0	19,0	100
	09	C8109002A	3,5 / 9,0	4,0 / 9,0	17	17	6,0	19,0	50
	11	C8111005A	3,5 / 11,0	7,0 / 11,0	20	20	6,0	21,0	50
	13	C8113009A	5,5 / 13,0	10,0 / 13,0	22	22	6,5	21,5	50
	16	C8116000A	6,5 / 15,0	10,0 / 15,0	24	24	6,5	23,5	50
	21	C8121004A	8,0 / 20,0	13,0 / 20,0	30	30	7,0	24,0	50
	29	C8129000A	12,5 / 29,0	20,0 / 29,0	40	40	8,0	38,0	10

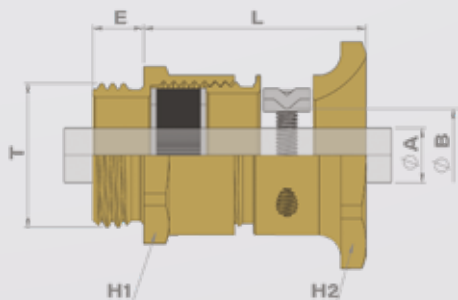

ZEV-B



	Thread T	Part Number	Clamping range		H1	H2	E	L	Packing
			Ø A (sealing)	Ø B (squeezing)					
Metric	16	C8216090	2,0 / 9,0	6,0 / 9,5	18	22	7,0	28,0	50
	20	C8220110	4,0 / 11,0	8,0 / 11,5	22	24	7,0	30,0	50
	20	C8220130	4,5 / 12,0	9,0 / 13,0	22	28	7,0	30,5	50
	25	C8225160	5,5 / 14,5	10,0 / 15,0	27	30	8,0	33,5	20
	25	C8225210	8,0 / 18,0	14,0 / 20,0	32	38	8,0	36,0	20
	32	C8232210	8,0 / 19,0	14,0 / 20,0	34	38	8,5	36,0	25
	32	C8232290	12,0 / 27,0	19,0 / 30,0	40	50	8,5	40,0	15
PG	09	C8209009A	2,0 / 9,0	6,0 / 9,5	17	22	6,0	28,0	50
	11	C8211002A	4,0 / 11,0	8,0 / 11,5	20	24	6,0	30,0	50
	13	C8213006A	4,5 / 12,0	9,0 / 13,0	22	28	6,5	30,5	50
	16	C8216007A	5,5 / 14,5	10,0 / 15,0	24	30	6,5	33,5	50
	21	C8221001A	8,0 / 19,0	14,0 / 20,0	30	38	7,0	36,0	50
	29	C8229007A	12,0 / 27,0	19,0 / 30,0	40	50	8,0	40,0	50