

LANGOFLEX NTW



LANGOFLEX NTW



Mechanical & Abrasion Protection

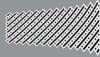

Expandable Sleeving



Braided



PA multifilament



Standard: Black



Low: -40°C (-40°F)
High: 125°C (257°F)



High extreme abrasion resistance

PHYSICAL PROPERTIES

| Physical properties | Spec | Value |
|-----------------------|---|-----------------------|
| Operating temperature | - | -40/125°C [-40/257°F] |
| Peak temperature | - | 150°C (302°F) |
| Abrasion resistance | SAE ARP 1536A | > 900 000 cycles |
| Flammability | FMVSS 302 SAE J 369 | self-extinguishing |
| Chemical resistance | Resists the majority of chemicals and automotive fluids | |

DIMENSIONS

| Designation | Nominal A Ø (inches) | Nominal A Ø (mm) | Maximum Ø (mm) |
|------------------|-------------------------|---------------------|-------------------|
| LANGOFLEX NTW 03 | 1/8" | 3 | 3 |
| LANGOFLEX NTW 05 | 3/16" | 5 | 5 |
| LANGOFLEX NTW 06 | 1/4" | 6 | 7 |
| LANGOFLEX NTW 08 | 5/16" | 8 | 9 |
| LANGOFLEX NTW 10 | 3/8" | 10 | 12 |
| LANGOFLEX NTW 13 | 1/2" | 13 | 18 |
| LANGOFLEX NTW 16 | 5/8" | 16 | - |
| LANGOFLEX NTW 19 | 3/4" | 19 | 22 |
| LANGOFLEX NTW 22 | 7/8" | 22 | 25 |
| LANGOFLEX NTW 25 | 1" | 25 | 32 |
| LANGOFLEX NTW 32 | 1 1/4" | 32 | 38 |
| LANGOFLEX NTW 38 | 1 1/2" | 38 | 50 |

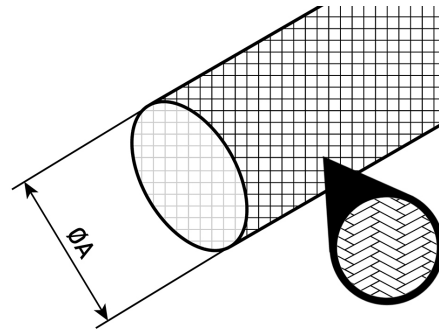

PACKAGING

Coils
Cut lengths upon request